

# HA2FM series axial piston

FIXED DISPLACEMENT MOTOR



hydraut

# HA2FM SERIES AXIAL PISTON

FIXED DISPLACEMENT MOTOR



## PRODUCT SHOW AND BRIEF INTRODUCTION

### Open and closed circuits

Series 6

Sizes 10...180

Nominal pressure 400 bar

Peak pressure 450 bar

### FEATURES

- Fixed displacement axial piston motor HA2FM, bent axis design, suitable for hydrostatic drives in open and closed circuits
- Use in mobile and industrial applications
- The output speed depends on the flow capacity of the pump and the displacement of the motor
- The torque increases with the pressure differential between the high and low pressure and side with increasing displacement
- Careful selection of the displacements offered, permit sizes to be matched to practically every application
- High power density
- Compact design
- High overall efficiency
- Excellent starting torque efficiency
- Economical conception
- One piece pistons with piston rings

### Model code

HA2F	M	80	/6	1	W	V	A	B	010
Axial Piston unit	Mode of operation	Size (cc/rev)	Series	Index	Direction of rotation	Seals	Shaft end	Mounting flange	Service line ports
HA2F: Bent axis design, fixed displacement	M: motor	23	6	1	(Viewed on shaft end) W: Alternating	V: FKM (fluorocautouch)	See below	B: 4-hole ISO 3019-2	See below
		28							
		32							
		45							
		56							
		63							
		80							
		90							
		107							
		125							
160									

### Shaft end

Size		23	28	32	45	56	63	80	90	107	125	160
Splined shaft DIN 5480	A	✓	✓	✓	✓	✓	✓	✓	✓	✓	✓	✓
	Z	✓	✓	x	✓	x	x	x	x	✓	x	✓
Parallel keyed shaft, DIN 6885	B	✓	✓	✓	x	✓	✓	✓	✓	x	x	x
	P	✓	✓	x	x	✓	x	✓	x	x	x	x

✓= available x= not available

Service line port

Port plates for service lines			23	28,32	45	56,63	80,90	107-125	160	
SAE flange ports A and B at rear	01	0	✓	✓	✓	✓	x	x	x	010
		7	x	x	x	x	x	x	x	017
SAE flange ports A and B at side, opposite	02	0	✓	✓	✓	✓	✓	✓	✓	020
		7	✓	✓	✓	✓	✓	x	x	027
		9	x	x	x	x	x	x	x	029
Threaded ports A and B at side, opposite	03	0	x	x	x	✓	x	x	x	030
Threaded ports A and B at side and rear		04	0	✓	✓	✓	x	x	x	040
SAE flange ports A and B at bottom (same side)	10	0	x	x	✓	✓	✓	✓	✓	100
Port plate with 1-level pressure-relief valves for mounting a counterbalance valve		BVD	17	x	x	x	x	x	x	x
	1		x	x	x	x	x	x	x	178
	BVE	18	8	x	x	x	x	✓	✓	181
Port plate with pressure-relief valves	19	1	x	x	x	x	x	x	x	191
		2	x	x	x	x	x	x	x	192

✓= available x= not available

Valves

Without valve	0	Flushing and boost pressure valve, mounted	7
Pressure-relief valve (without pressure boost facility)	1	Counterbalance valve BD/BVE mounted	8
Pressure-relief valve (with pressure boost facility)	2	Flushing and boost pressure valve, integrated	9

TECHNICAL DATA

Hydraulic fluid

The HA2FM fixed displacement motor is suitable for use with mineral oil.

Viscosity range

We recommend a viscosity (at operating temperature) for optimum efficiency and service life purposes of

$$V_{opt} = \text{optimum viscosity } 16 \dots 36 \text{ mm}^2/\text{s}$$

Be chosen, taken the circulation temperature (closed circuit) and tank temperature (open circuit) into account.

Limits of viscosity range

The following values apply in extreme cases:

$$V_{min} = 5 \text{ mm}^2/\text{s} \text{ short term (} t < 3 \text{ min) at max. permitted temperature } t_{max} = 115^\circ\text{C}$$

$$V_{max} = 1600 \text{ mm}^2/\text{s} \text{ short term (} t < 3 \text{ min) with cold start (} P < 30 \text{ bar, } n < 1000 \text{ rpm } t_{min} = -40^\circ\text{C)}$$

Note that the maximum hydraulic fluid temperature must not be exceeded locally either (e.g. bearing area).

The temperature in the bearing area is depending on pressure and speed-up to 12 K higher than the average case drain temperature.

Selection diagram

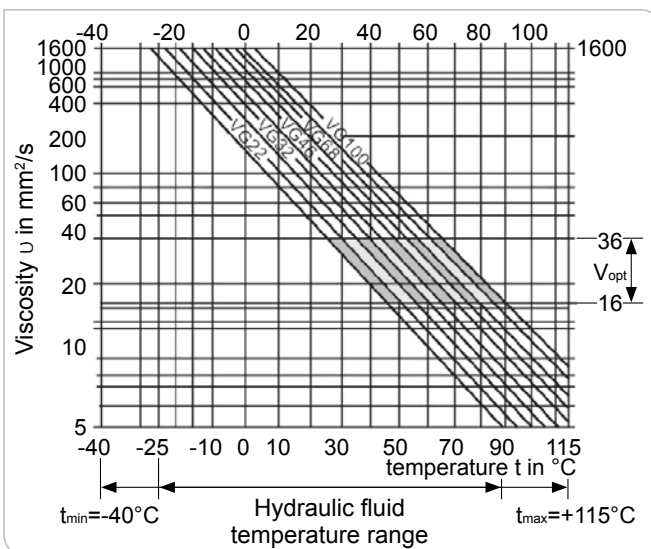

Details regarding the choice of hydraulic fluid

The correct choice of pressure fluid requires knowledge of the operating temperature in relation to the ambient temperature: in closed circuit the circulation temperature, in an open circuit the tank temperature. The hydraulic fluid should be selected so that within the operating temperature range, the operating viscosity lies within the optimum range ( $V_{opt}$ ) (see shaded section of the selection diagram). We recommend that the highest possible viscosity range should be chosen in each case.

## TECHNICAL DATA

**Example:** at an ambient temperature of X°C an operating temperature of 60°C is set in the circuit. In the optimum operating viscosity range ( $V_{opt}$ ; shaded area) this corresponds to the viscosity classes VG 46 or VG 68; to be selected: VG 68.

**Please note:** the leakage fluid temperature, which is affected by pressure and rotational speed, is always higher than the circulation temperature or tank temperature. At no point in the system may the temperature be higher than 115°C.

### Filtration

The finer the filtration, the cleaner the fluid and the longer the service life of the axial piston unit.

To ensure proper function of the axial piston unit, the hydraulic fluid must have a cleanliness level of at least.

20/18/15 according to ISO 4406

At very high hydraulic fluid temperatures (90°C to max.115°C), a cleanliness level of at least

19/17/14 according to ISO 4406 is required

Please contact us if these cleanliness levels cannot be achieved.

### Operational pressure range

Maximum pressure on port A or B (pressure data according to DIN 24312)

	Shaft end A, Z	Shaft end B, P
Nominal pressure $P_N$	400 bar	350 bar
Peak pressure $P_{max}$	450 bar	400 bar
Summation pressure (A+B)	700 bar	700 bar

Please note: at the shaft end Z and P, a nominal pressure of  $P_N=315$  bar ( $P_{max}=350$  bar) is permitted for the driven shaft end that is subjected to transverse bending (pinions, V-belts)

Size 56 with shaft end Z:  $P_N=350$  bar,  $P_{max}=400$  bar

in cases of pulsating loading above 315 bar, we recommend the version with splined shaft A or splined shaft Z (sizes 45).

### Direction of flow

Direction of rotation, viewed on shaft end.

clockwise	counter-clockwise
A to B	B to A

### Speed range

No limit to minimum speed  $n_{min}$ . If uniform motion is required,  $n_{min}$  must not be less than 50 rpm.

### Shaft seal ring

#### Permissible pressure load

The service life of the shaft seal ring is affected by the speed of the motor and the case drain pressure. The permitted loading with intermittent case drain pressure depends on the rotational speed (see chart). Short-term ( $t < 5$  min) pressure spikes of up to 10 bar absolute are permitted.

The average permanent case drain pressure must not exceed 3 bar absolute.

The pressure in the case must be equal to or greater than the external pressure on the shaft seal.

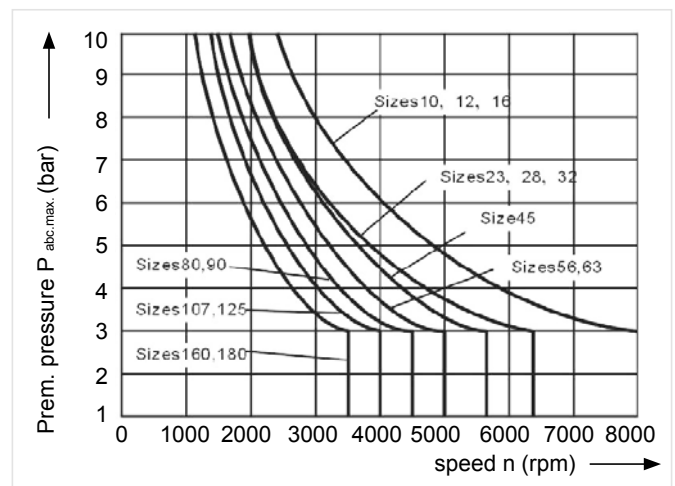

### Temperature range

The FKM shaft seal is admissible for a housing temperature range from -25°C to +115°C.

TECHNICAL DATA

Table of values (theoretical values, ignoring nmin and nv; values rounded)

Size				23	28	32	45
Displacement		Vg	cc/rev	22,9	28,1	32,0	45,6
Speed max		Nmax	min-1	6300	6300	6300	5600
		Nmax limit (1)	min-1	6900	6900	6900	6200
Flow max.		q vmax	L/min	144	176	201	255
Torque constants		Tk	Nm/bar	3,6	4,45	5,09	7,25
Torque at	Δ P=350 bar	T	Nm	126	156	178	254
	Δ P=400 bar	T	Nm	144	178	204	290
Filling capacity			L	0,20	0,20	0,20	0,33
Mass moment of inertia around output shaft		J	kgm <sup>2</sup>	0,0012	0,0012	0,0012	0,0024
Mass (approx.)			kg	9,5	9,5	9,5	13,5

Size				56	63	80	90	107	125	160
Displacement		Vg	cc/rev	56,1	63	80,4	90	106,7	125	160,4
Speed max		Nmax	min-1	5000	5000	4500	4500	4000	4000	3600
		Nmax limit (1)	min-1	5500	5500	5000	5000	4400	4400	4000
Flow max.		q vmax	L/min	280	315	360	405	427	500	577
Torque constants		Tk	Nm/bar	8,9	10	12,7	17	19,9	25,4	28,6
Torque at	Δ P=350 bar	T	Nm	312	350	445	501	595	697	889
	Δ P=400 bar	T	Nm	356	400	508	572	680	796	1016
Filling capacity			L	0,45	0,45	0,55	0,55	0,8	0,8	1,1
Mass moment of inertia around output shaft		J	kgm <sup>2</sup>	0,0042	0,0042	0,0072	0,0072	0,0116	0,0116	0,0220
Mass (approx.)			kg	18	18	23	23	32	32	45

1) intermittent maximum speed: overspeed at discharge and over-running travel operations, t<5 sec. and AP<150 bar

Determining the size

Flow  $q_v = \frac{V_g \cdot n}{1000 \cdot \eta_v}$  [L/min]  $V_g =$  Displacement per revolution in mL/r  
 $\Delta P =$  Differential pressure in bar

Speed  $n = \frac{q_v \cdot 1000 \cdot \eta_v}{V_g}$  [rpm]  $n =$  Speed in rpm  
 $\eta_v =$  Volumetric efficiency



Torque  $T = \frac{V_g \cdot \Delta P \cdot \eta_{mh}}{20\pi}$  [Nm]  $\eta_{mh} =$  Mechanical-hydraulic efficiency  
 $\eta_t =$  Overall efficiency

Power  $P = \frac{2\pi \cdot T \cdot n}{60000} = \frac{q_v \cdot \Delta P}{600 \cdot \eta_t}$  [kW]

Permissible radial and axial loading on the drive shaft

The values given are maximum values and do not apply to continuous operation

Size				23	28	32	45	56
Radial force, max. at distance a (from shaft collar) <sup>(1)</sup>		$F_{qmax}$	N	4300	5400	6100	8150 <sup>(2)</sup>	9200 <sup>(2)</sup>
		a	mm	16	16	16	18	18
Axial force, max. <sup>(3)</sup>		+ $F_{ax max}$	N	500	500	500	630	800
		- $F_{ax max}$	N	500	500	500	630	800
Permissible axial force/bar operating pressure		$\pm F_{ax per bar}$	N/bar	52	52	52	70	87

Size				63	80	90	107	125	160
Radial force, max. at distance a (from shaft collar) <sup>(1)</sup>		$F_{qmax}$	N	10300	11500 <sup>(2)</sup>	12900	13600	15900	18400
		a	mm	18	20	20	20	20	25
Axial force, max. <sup>(3)</sup>		+ $F_{ax max}$	N	800	1000	1000	12500	1250	1600
		- $F_{ax max}$	N	800	1000	1000	12500	1250	1600
Permissible axial force/bar operating pressure		$\pm F_{ax per bar}$	N/bar	87	106	106	129	129	167

- 1) During intermittent operation
- 2) Permissible max. radial force with shaft end Z:  $F_{qmax} = 6500N$
- 3) Max. permissible axial force when stopped or when axial piston unit working in pressureless conditions

When considering the permissible axial force, the force-transfer direction must be taken into account:

- $F_{ax max}$  = increase in service life of bearings
- +  $F_{ax max}$  = reduction in service life of bearings (avoid if at all possible)

Minimum inlet pressure on service line port A (B)

In order to avoid damage of the motor a minimum inlet pressure at the inlet zone must be assured. The minimum inlet pressure is related to the rotational speed of the fixed motor.

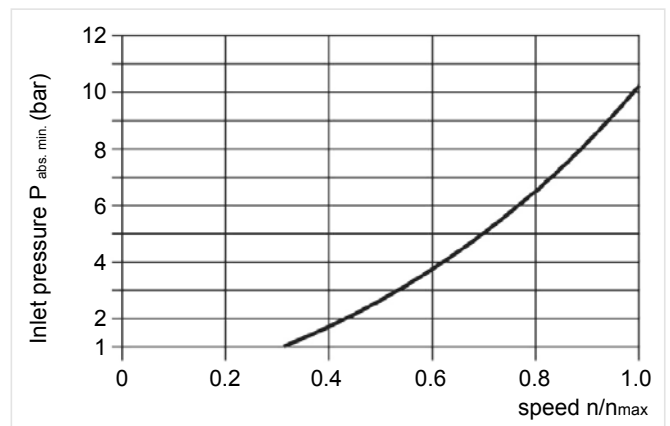

DIMENSIONS: SIZES 23, 28, 32

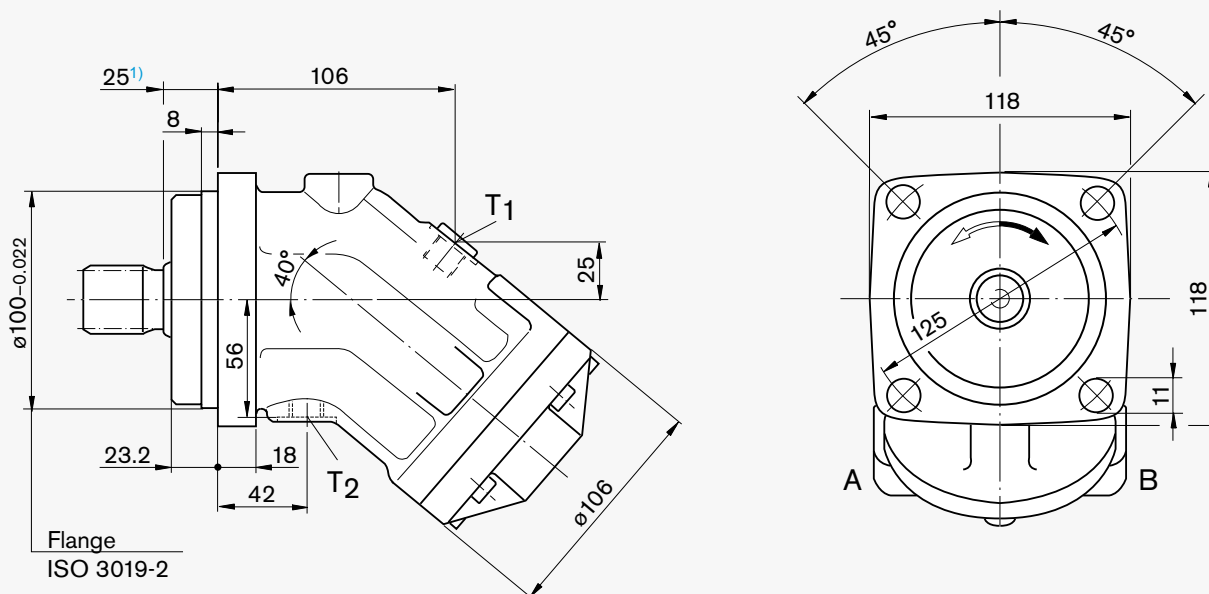

HA2FM

DRIVE SHAFTS

NG 23, 28, 32

A Splined shaft DIN 5480  
W30 x 2 x 14 x 9g

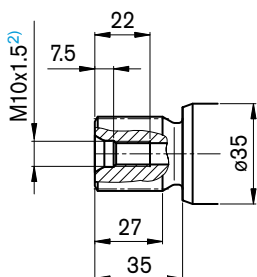

NG 23, 28

Z Splined shaft DIN 5480  
W25 x 1.25 x 18 x 9g

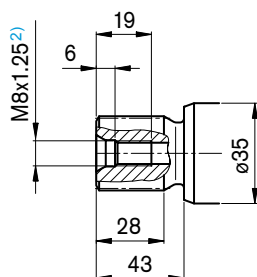

NG 23, 28, 32

B Parallel keyed shaft,  
DIN 6885, AS8 x 7 x 40

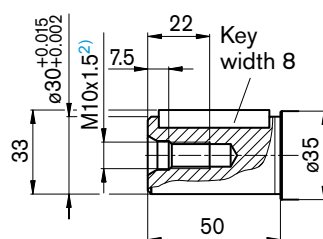

NG 23, 28

P Parallel keyed shaft  
DIN 6885, AS8 x 7 x 40

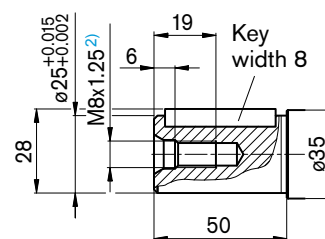

PORTS

Designation	Port for	Standard	Size	Maximum pressure (bar) <sup>(3)</sup>	STATE <sup>(6)</sup>
A, B	Service line (see port plates)	-	-	450	-
T <sub>1</sub>	Drain line	DIN 3852 <sup>(5)</sup>	M16 x 1.5; 12 deep	3	X <sup>(4)</sup>
T <sub>2</sub>	Drain line	DIN 3852 <sup>(5)</sup>	M16 x 1.5; 12 deep	3	O <sup>(4)</sup>

1) To shaft collar

2) Center bore according to DIN 332 (thread according to DIN 13)

3) Momentary pressure spikes may occur depending on the application. Keep this in mind when selecting measuring devices and fittings

4) Depending on installation position, T1 or T2 must be connected

5) The spot face can be deeper than specified in the appropriate standard

6) O = Must be connected (plugged on delivery)  
X = Plugged (in normal operation)

Location of the service line ports on the port plates

01 SAE flange ports at rear

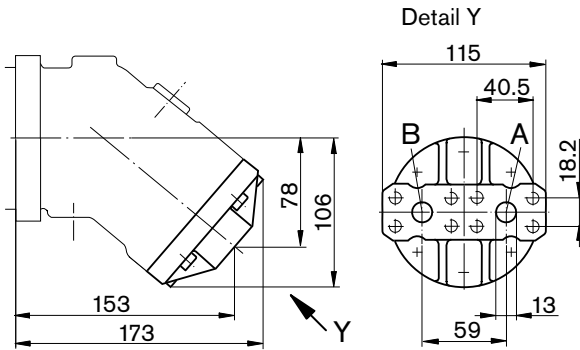

02 SAE flange ports at side, opposite

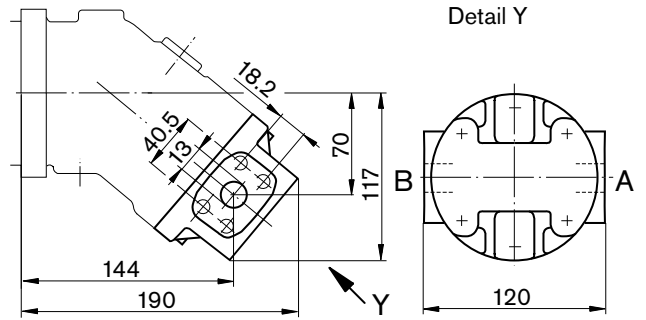

04 Threaded ports at side and rear<sup>3)</sup>

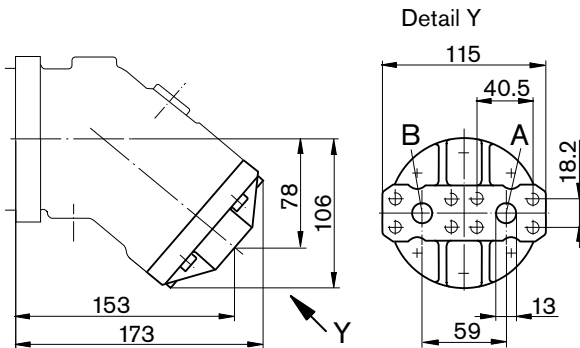

Plate	Designation	Port for	Standard	Size	Maximum pressure (bar) <sup>(1)</sup>	STATE <sup>(5)</sup>
01, 02, 10	A, B	Service line	SAE J518 <sup>(2)</sup>	1/2 in M8 x 1.25; 15 deep	450	O
03		Fastening thread A/B	DIN 13			
04		Service line	DIN 3852 <sup>(4)</sup>	M27 x 2; 16 deep	450	1x O each

1) Momentary pressure spikes may occur depending on the application. Keep this in mind when selecting measuring devices and fittings

2) Only dimensions according to SAE J518, metric fastening thread is a deviation from standard

3) Only sizes 28 and 32

4) The spot face can be deeper than specified in the appropriate standard

5) O = Must be connected (plugged on delivery)



DIMENSIONS: SIZE 45

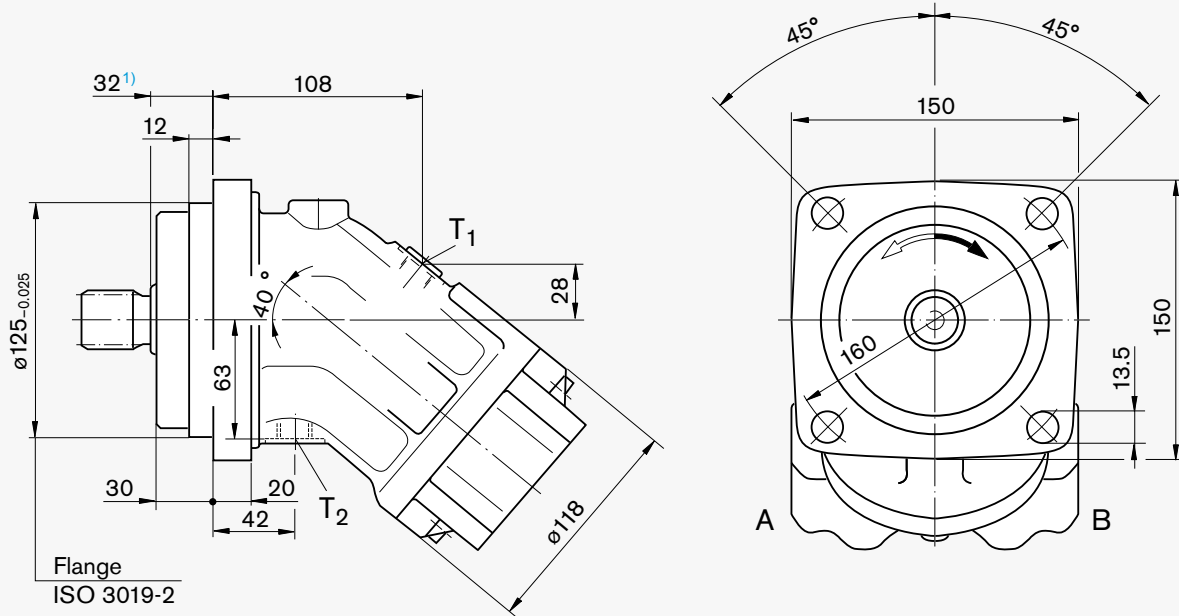

DRIVE SHAFTS

NG 45

Z Splined shaft DIN 5480  
W30 x 2 x 14 x 9g

SHAFT A: Drawing on request

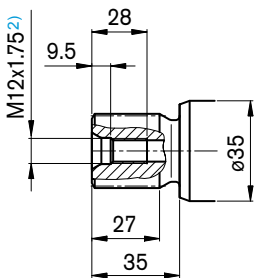

PORTS

Designation	Port for	Standard	Size	Maximum pressure (bar) <sup>(3)</sup>	STATE <sup>(6)</sup>
A, B	Service line (see port plates)	-	-	450	-
T <sub>1</sub>	Drain line	DIN 3852 <sup>(5)</sup>	M18 x 1.5; 12 deep	3	X <sup>(4)</sup>
T <sub>2</sub>	Drain line	DIN 3852 <sup>(5)</sup>	M18 x 1.5; 12 deep	3	O <sup>(4)</sup>

1) To shaft collar

2) Center bore according to DIN 332 (thread according to DIN 13)

3) Momentary pressure spikes may occur depending on the application. Keep this in mind when selecting measuring devices and fittings

4) Depending on installation position, T1 or T2 must be connected.

5) The spot face can be deeper than specified in the appropriate standard

6) O = Must be connected (plugged on delivery)  
X = Plugged (in normal operation)

Location of the service line ports on the port plates

01 SAE flange ports at rear

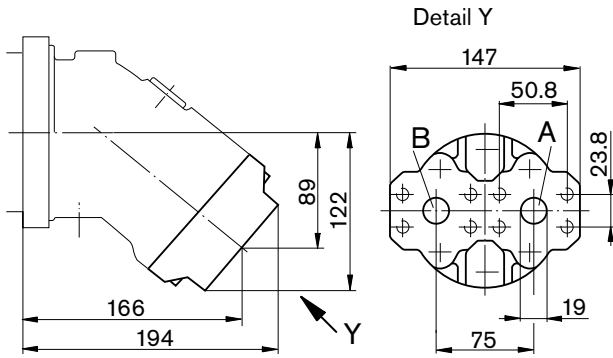

02 SAE flange ports at side, opposite

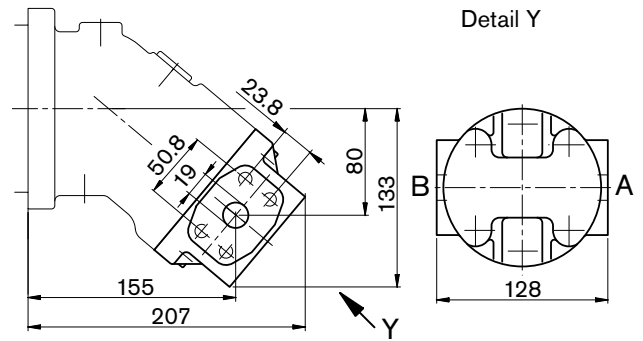

04 Threaded ports at side and rear

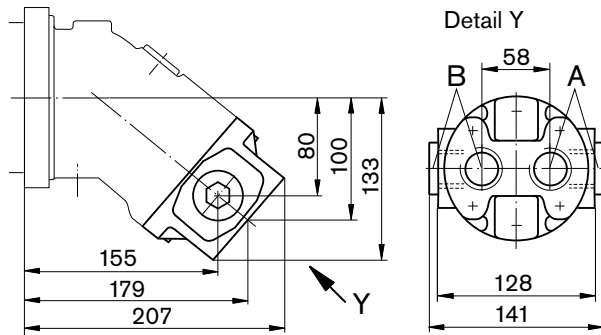

10 SAE flange ports at bottom (same side)

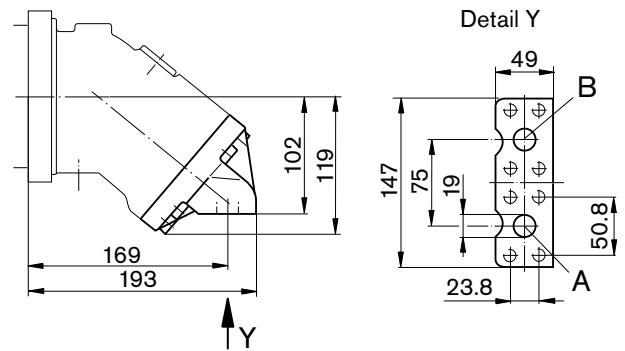
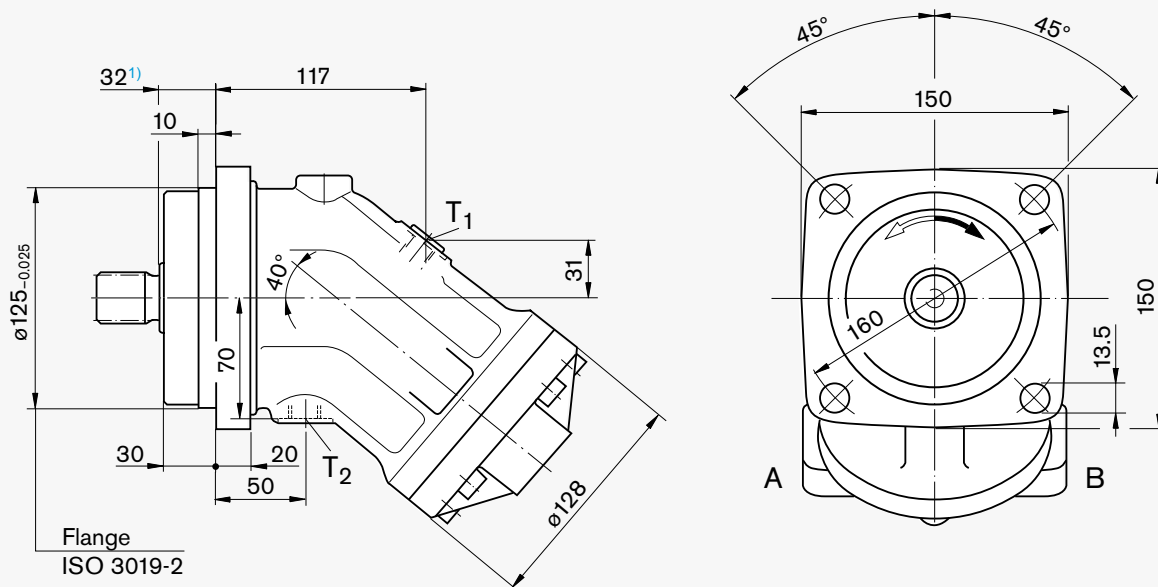

Plate	Designation	Port for	Standard	Size	Maximum pressure (bar) <sup>(1)</sup>	STATE <sup>(4)</sup>
01, 02, 10	A, B	Service line	SAE J518 <sup>(2)</sup>	3/4 in	450	O
		Fastening thread A/B	DIN 13	M10 x 1.5; 17 deep		
04		Service line	DIN 3852 <sup>(3)</sup>	M33 x 2; 18 deep	450	1 x O each

- 1) Momentary pressure spikes may occur depending on the application. Keep this in mind when selecting measuring devices and fittings
- 2) Only dimensions according to SAE J518, metric fastening thread is a deviation from standard

- 3) The spot face can be deeper than specified in the appropriate standard
- 4) O = Must be connected (plugged on delivery)

DIMENSIONS: SIZES 56, 63



HA2FM

DRIVE SHAFTS

NG 56, 63

A Splined shaft DIN 5480  
W35 x 2 x 16 x 9g

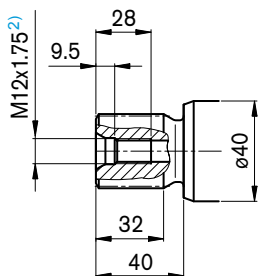

NG 56, 63

B Parallel keyed shaft  
DIN 6885, AS10 x 8 x 50

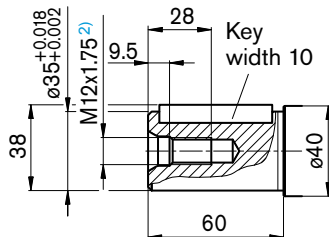

NG 56

P Parallel keyed shaft,  
DIN 6885, AS8 x 7 x 50

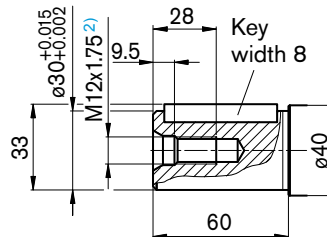

PORTS

Designation	Port for	Standard	Size	Maximum pressure (bar) <sup>(3)</sup>	STATE <sup>(6)</sup>
A, B	Service line (see port plates)	-	-	450	-
T <sub>1</sub>	Drain line	DIN 3852 <sup>(5)</sup>	M18 x 1.5; 12 deep	3	X <sup>(4)</sup>
T <sub>2</sub>	Drain line	DIN 3852 <sup>(5)</sup>	M18 x 1.5; 12 deep	3	O <sup>(4)</sup>

1) To shaft collar

2) Center bore according to DIN 332 (thread according to DIN 13)

3) Momentary pressure spikes may occur depending on the application. Keep this in mind when selecting measuring devices and fittings

4) Depending on installation position, T1 or T2 must be connected

5) The spot face can be deeper than specified in the appropriate standard

6) O = Must be connected (plugged on delivery)  
X = Plugged (in normal operation)

Location of the service line ports on the port plates

01 SAE flange ports at rear

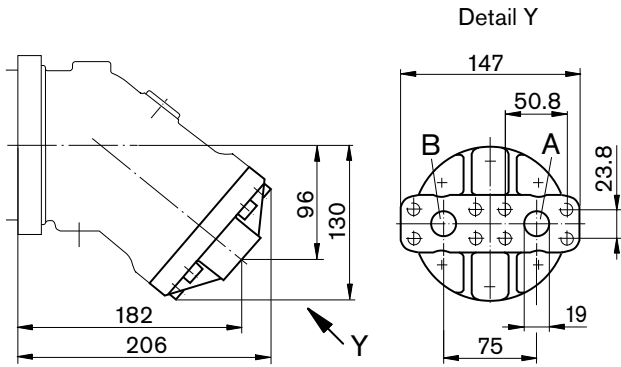

02 SAE flange ports at side, opposite

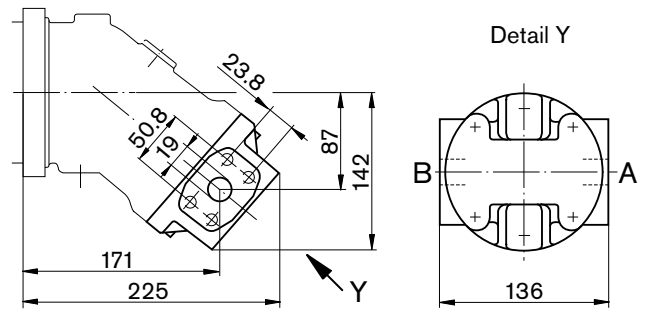

03 Threaded ports at side, opposite

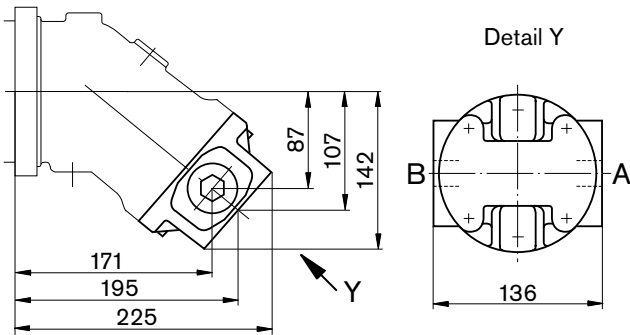

10 SAE flange ports at bottom (same side)

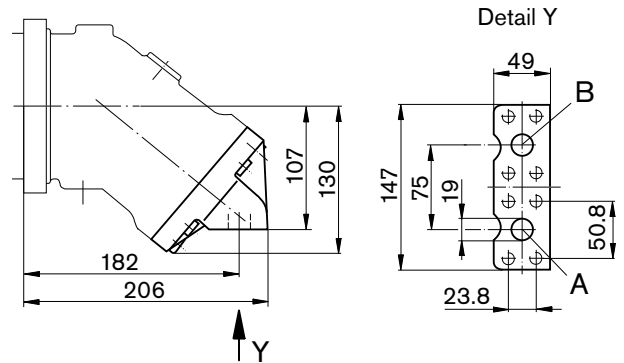
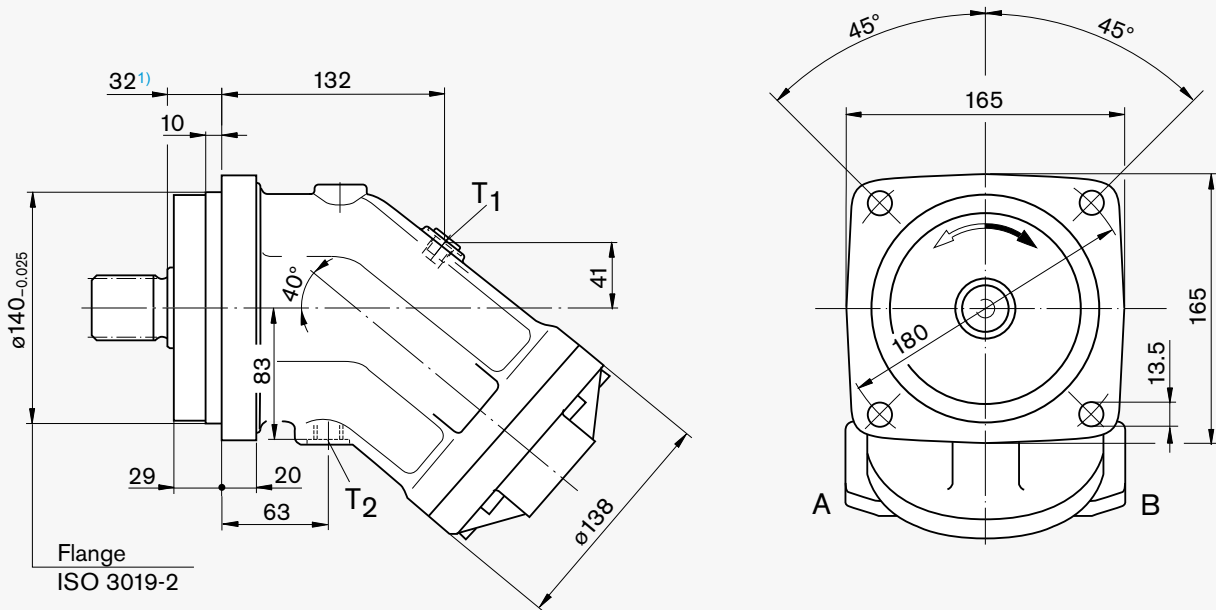

Plate	Designation	Port for	Standard	Size	Maximum pressure (bar) <sup>(1)</sup>	STATE <sup>(4)</sup>
01, 02, 10	A, B	Service line Fastening thread A/B	SAE J518 <sup>(2)</sup> DIN 13	3/4 in M10 x 1.5; 17 deep	450	O
04		Service line	DIN 3852 <sup>(3)</sup>	M33 x 2; 18 deep	450	1 x O each

- 1) Momentary pressure spikes may occur depending on the application. Keep this in mind when selecting measuring devices and fittings
- 2) Only dimensions according to SAE J518, metric fastening thread is a deviation from standard

- 3) The spot face can be deeper than specified in the appropriate standard
- 4) O = Must be connected (plugged on delivery)

DIMENSIONS: SIZES 80, 90



DRIVE SHAFTS

NG 80, 90

A Splined shaft DIN 5480  
W40 x 2 x 18 x 9g

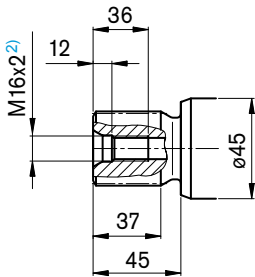

NG 80, 90

B Parallel keyed shaft  
DIN 6885, AS12 x 8 x 56

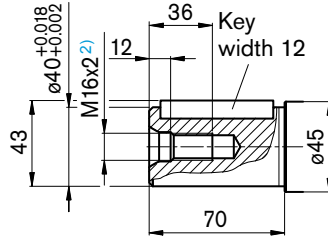

NG 80

P Parallel keyed shaft,  
DIN 6885, AS10 x 8 x 56

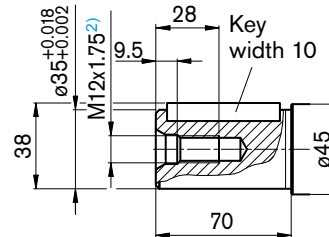

PORTS

Designation	Port for	Standard	Size	Maximum pressure (bar) <sup>(3)</sup>	STATE <sup>(6)</sup>
A, B	Service line (see port plates)	-	-	450	-
T <sub>1</sub>	Drain line	DIN 3852 <sup>(5)</sup>	M18 x 1.5; 12 deep	3	X <sup>(4)</sup>
T <sub>2</sub>	Drain line	DIN 3852 <sup>(5)</sup>	M18 x 1.5; 12 deep	3	O <sup>(4)</sup>

1) To shaft collar

2) Center bore according to DIN 332 (thread according to DIN 13)

3) Momentary pressure spikes may occur depending on the application. Keep this in mind when selecting measuring devices and fittings

4) Depending on installation position, T1 or T2 must be connected

5) The spot face can be deeper than specified in the appropriate standard

6) O = Must be connected (plugged on delivery)  
X = Plugged (in normal operation)

Location of the service line ports on the port plates

02 SAE flange ports at side, opposite

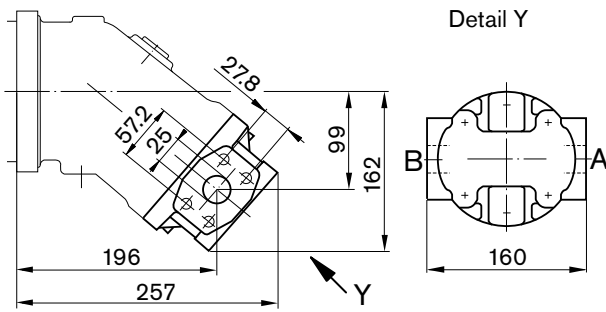

10 SAE flange ports at bottom (same side)

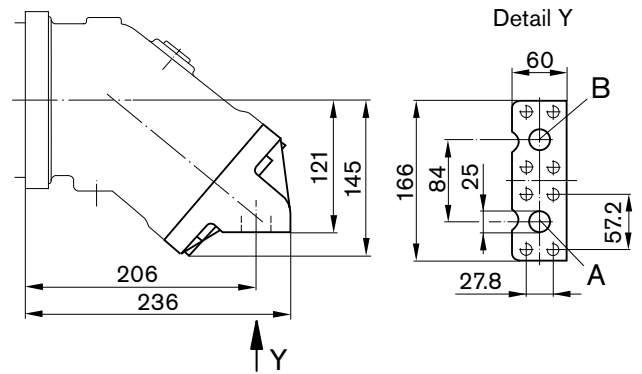
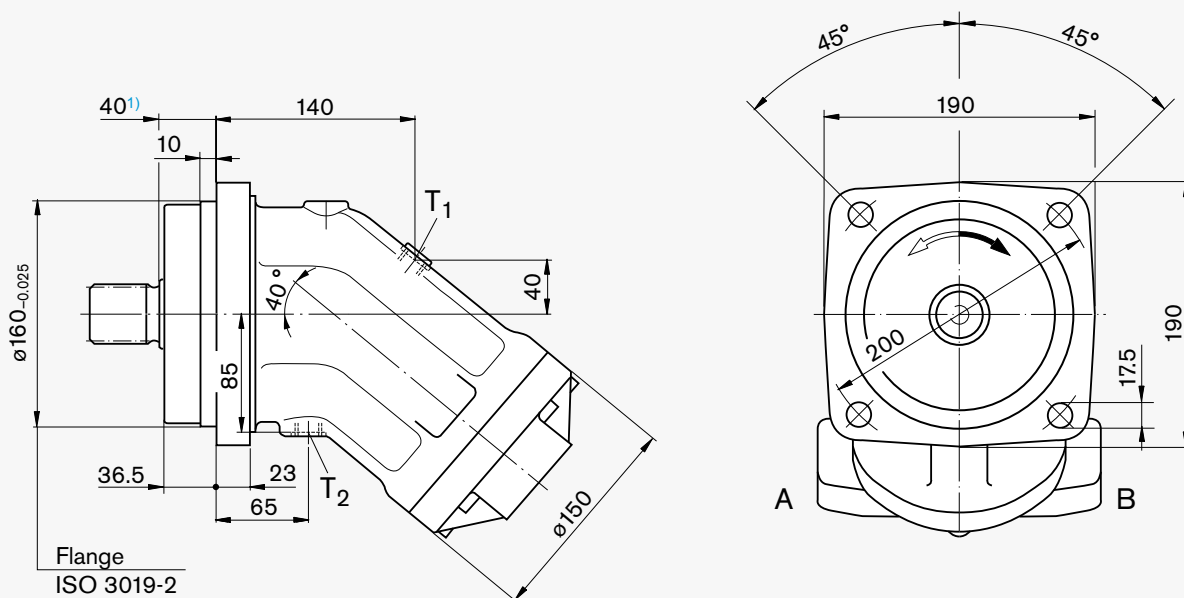

Plate	Designation	Port for	Standard	Size	Maximum pressure (bar) <sup>(1)</sup>	STATE <sup>(3)</sup>
01, 02, 10	A, B	Service line Fastening thread A/B	SAE J518 <sup>(2)</sup> DIN 13	1 in M12 x 1.75; 17 deep	450	O

- 1) Momentary pressure spikes may occur depending on the application. Keep this in mind when selecting measuring devices and fittings.
- 2) Only dimensions according to SAE J518, metric fastening thread is a deviation from standard.
- 3) O = Must be connected (plugged on delivery)

DIMENSIONS: SIZES 107, 125



Flange  
ISO 3019-2

HA2FM

DRIVE SHAFTS

NG 107, 125

A Splined shaft DIN 5480  
W45 x 2 x 21 x 9g

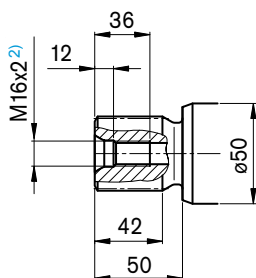

NG 107

Z Splined shaft DIN 5480  
W40 x 2 x 18 x 9g

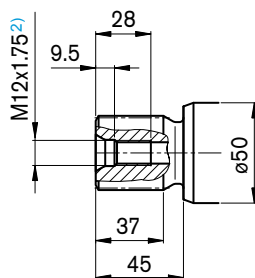

PORTS

Designation	Port for	Standard	Size	Maximum pressure (bar) <sup>(3)</sup>	STATE <sup>(6)</sup>
A, B	Service line (see port plates)	-	-	450	-
T <sub>1</sub>	Drain line	DIN 3852 <sup>(5)</sup>	M18 x 1.5; 12 deep	3	X <sup>(4)</sup>
T <sub>2</sub>	Drain line	DIN 3852 <sup>(5)</sup>	M18 x 1.5; 12 deep	3	O <sup>(4)</sup>

1) To shaft collar

2) Center bore according to DIN 332 (thread according to DIN 13)

3) Momentary pressure spikes may occur depending on the application. Keep this in mind when selecting measuring devices and fittings

4) Depending on installation position, T1 or T2 must be connected

5) The spot face can be deeper than specified in the appropriate standard

6) O = Must be connected (plugged on delivery)  
X = Plugged (in normal operation)

Location of the service line ports on the port plates

02 SAE flange ports at side, opposite (size 107)

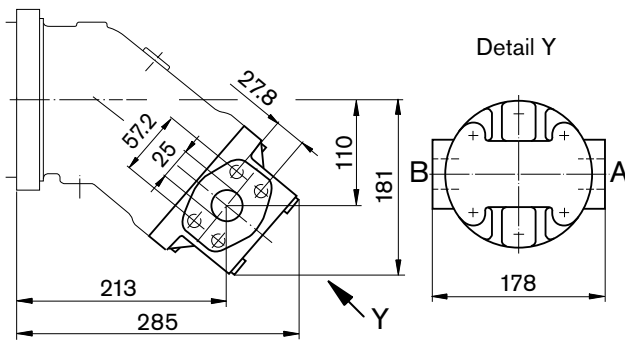

10 SAE flange ports at bottom (same side)

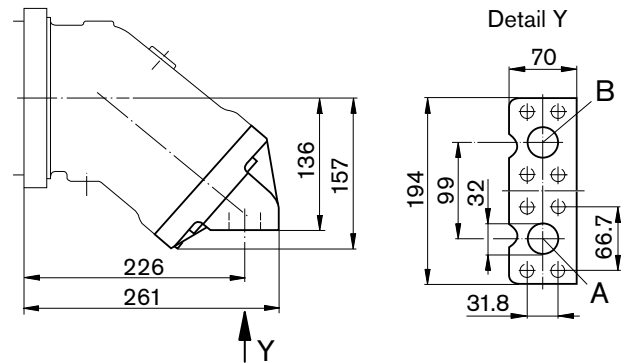

02 SAE flange ports at side, opposite (size 125)

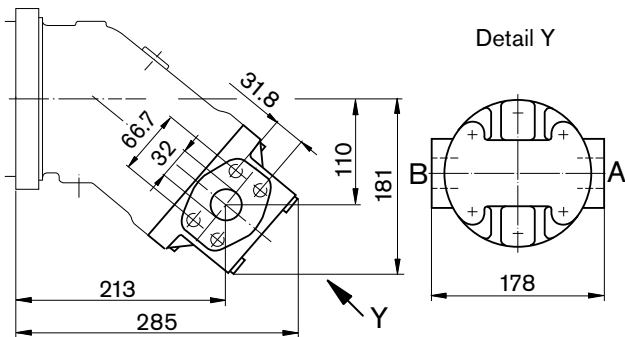

PORT PLATE 188: Drawing on request

Plate	Designation	Port for	Standard	Size	Maximum pressure (bar) <sup>(1)</sup>	STATE <sup>(3)</sup>
01, 10	A, B	Service line	SAE J518 <sup>(2)</sup>	1 1/4 in	450	O
		Fastening thread A/B	DIN 13	M14 x 2; 19 deep		
02 (size 107)		Service line	SAE J518 <sup>(2)</sup>	1 in		
		Fastening thread A/B	DIN 13	M12 x 1,75; 17 deep	450	O
02 (size 125)		Service line	SAE J518 <sup>(2)</sup>	1 in	450	O
		Fastening thread A/B	DIN 13	M14 x 2; 19 deep		

1) Momentary pressure spikes may occur depending on the application. Keep this in mind when selecting measuring devices and fittings

2) Only dimensions according to SAE J518, metric fastening thread is a deviation from standard

3) O = Must be connected (plugged on delivery)



DIMENSIONS: SIZE 160

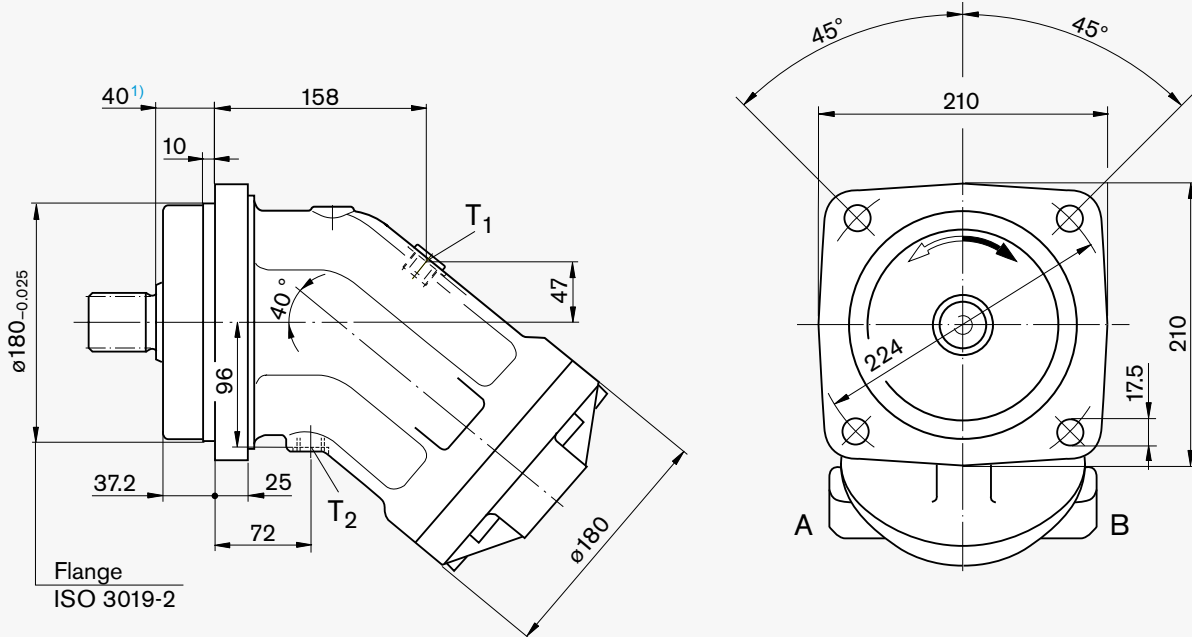

Flange  
ISO 3019-2

DRIVE SHAFTS

NG 160

A Splined shaft DIN 5480  
W50 x 2 x 24 x 9g

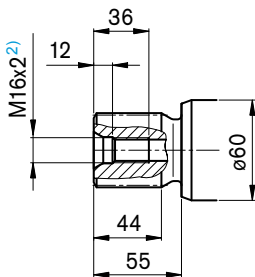

NG 160

Z Splined shaft DIN 5480  
W45 x 2 x 21 x 9g

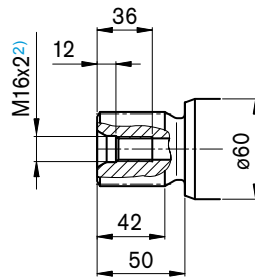

PORTS

Designation	Port for	Standard	Size	Maximum pressure (bar) <sup>(3)</sup>	STATE <sup>(6)</sup>
A, B	Service line (see port plates)	-	-	450	-
T1	Drain line	DIN 3852 <sup>(5)</sup>	M22 x 1.5; 14 deep	3	X <sup>(4)</sup>
T2	Drain line	DIN 3852 <sup>(5)</sup>	M22 x 1.5; 14 deep	3	O <sup>(4)</sup>

1) To shaft collar

2) Center bore according to DIN 332 (thread according to DIN 13)

3) Momentary pressure spikes may occur depending on the application. Keep this in mind when selecting measuring devices and fittings

4) Depending on installation position, T1 or T2 must be connected

5) The spot face can be deeper than specified in the appropriate standard

6) O = Must be connected (plugged on delivery)  
X = Plugged (in normal operation)

Location of the service line ports on the port plates

02 SAE flange ports at side, opposite

PORT PLATES 188: Drawing on request

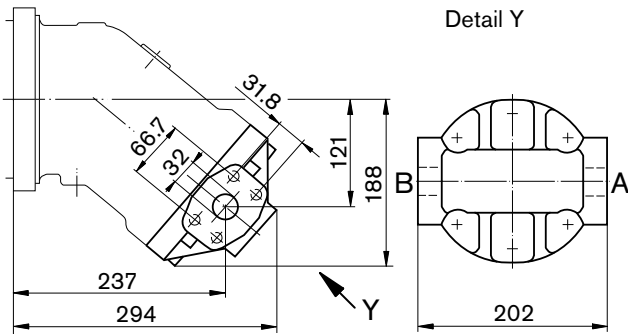

Plate	Designation	Port for	Standard	Size	Maximum pressure (bar) <sup>(1)</sup>	STATE <sup>(3)</sup>
01, 02, 10	A, B	Service line Fastening thread A/B	SAE J518 <sup>(2)</sup> DIN 13	1 1/4 in M14 x 2; 19 deep	450	O

1) Momentary pressure spikes may occur depending on the application. Keep this in mind when selecting measuring devices and fittings

2) Only dimensions according to SAE J518, metric fastening thread is a deviation from standard.

3) O = Must be connected (plugged on delivery)

INSTALLATION AND COMMISSIONING NOTES

General

The motor case must be completely filled up with hydraulic fluid during startup and during operation (filling the case chamber). The motor must be started up at low speed and no load until the system has been bled completely.

If stopped for an extended period, fluid may drain out of the case through the service lines. When restarting, make sure that

the case contains sufficient fluid.

The leakage fluid inside the case chamber must be drained off to the tank through the highest case drain port.

Installation position

Optional. With installation position “shaft to the top” use motor with bleeding port R.

Installation below the tank

Motor below min. fluid level in the tank (standard)

- Fill axial piston motor before startup via the highest case drain port
- Run the motor at low speed until the system is bled completely (bleed through service line port A, B if tubing is long)
- Minimum immersion depth of leakage line in tank: 200mm (relative to the min. fluid level in the tank)
- Additional measures required for installation position 2 (shaft facing up); with installation position 2, make sure that the motor case is completely full before starting up. Bleed at port R.

An air pocket in the bearing area is leading to damage of the axial piston motor

Installation above the tank

Motor above min. fluid level in tank

- Proceed in same way as below the tank installation
- Additional measures for installation position 1 and 2: if it is topped for an extended period, fluid may drain out of the case chamber through the service lines (air enters through the shaft seal). The bearing will therefore not be properly lubricated when the motor is started up again. Fill the axial piston motor before restarting via the highest case drain port. Installation position 2: bleed at port R.
- Additional measures required for installation position 2 (shaft facing up).

In this installation position the bearings will not be properly lubricated, even if there is still some fluid in the case chamber. Putting a non-return valve (opening pressure 0.5 bar) in the leakage line can prevent the system emptying through the line

